

Contact us now for solutions to a wide range of storage requirements including the storage of any of the following materials:

- Files and Paper Records
- Digital Storage Media
- Archive Boxes / Box Files
- Maps / Manuscripts
- Pictures
- Garment Hanging
- Small Parts
- Bulk Storage

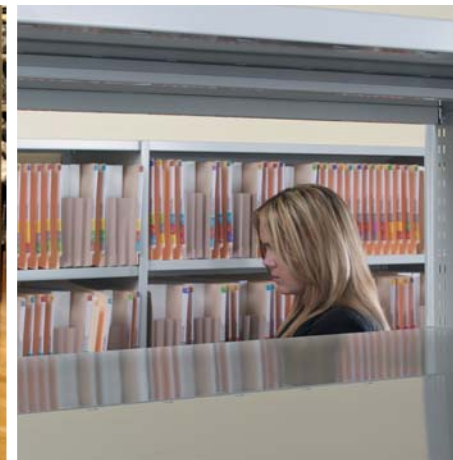

# NEW Stormor® Shelving

the *only* storage system you will ever need



## LINK 51 FAMOUS FOR LOCKERS AND STORAGE PRODUCTS

### Shelving & Storage

Link 51 (Storage Products)  
 Link House, Halesfield 6  
 Telford, Shropshire, England TF7 4LN  
 Tel: 0800 515 600  
 Fax: 01952 680 352  
 E-mail: shelving@link51.co.uk  
 Web: www.link51.co.uk



Certificate No. FM 22837



Corporate Sponsor



Note: This publication shows general concepts only, and should not be used as a guide for specific design or assembly purposes. Link 51 reserves the right to alter the specification on any of these products, in the customers interest, without prior notification.



# Stormor® Shelving

**ONE** System  
**HUNDREDS** of solutions...

Choice of frame styles to match the storage requirement.

Easy-fit accessories to enhance the basic system.

Accessories are interchangeable with all frame styles - giving total versatility within the installation as storage requirements change.

Aesthetically pleasing slim profile shelves and frames.

Minimum number of components offering maximum choice of solutions.

Wide range of shelf and frame sizes for both general and specific requirements.

Duo frame is compliant to standard BS5454.



## Stormor® Shelving

### The only Storage System you will ever need

Delivering the optimum solution for your storage requirements



## company profile

Established as The Handy Angle Company in 1951 by father and son Joe and Peter Kinnear, Link 51 is now widely recognised as the largest manufacturer of Shelving, Pallet Racking and Lockers in the UK.

With Link 51 having now celebrated over 50 years of trading, the company has steadily grown its reputation and market share over the years by developing an ever-improving range of products to solve the many and varied storage & handling problems encountered daily throughout industry and commerce.

The company currently operates manufacturing sites at Brierley Hill (on the site of the original Handy Angle Co. premises), and at Telford in Shropshire. These facilities provide significant capacity of manufacture and supply of steel shelving & racking systems. Telford is also the location of Link Lockers, a 'sister' company to Link 51 specialising in personal storage lockers.

Link 51 provides a wide range of high quality storage equipment, reliable products proven and well-established in their markets, including the original 'Handy Angle'; warehouse pallet racking; static & mobile shelving; plastic containers; personal storage lockers; workbenches; and drawer storage cabinets.

### quality assurance

Link 51 is committed to maintaining high quality standards in the company's products & services. This commitment was first substantiated in January 1987 by Link 51's registration with The British Standards Institute as a 'Firm of Assessed Capability' in accordance with Quality Assessment Schedule No. 3204/274 and BS EN ISO 9000 (formerly BS5750 part 1). Link 51's current system operates in accordance with BS EN ISO 9001:2000 and QAS 2000.



Handy Angle - Link 51's original product. Some 150,00 feet of this versatile, bolted steel angle section is still manufactured each week



The Shelving & Storage factory at Brierley Hill - once the site of the founding Handy Angle Company



International Headquarters







## designed for today's working practices

**Stormor Shelving** is the solution to the requirements of office or departmental storage, particularly for 'live' documents and reference material that needs to be kept close at hand.

Having the right storage system is key to operating an effective document and data management system.

This is especially true now that the Data Protection Act and Freedom of Information acts are coming into force, placing further pressures on companies to comply quickly and efficiently.

Whether it is a small number of storage bays or the most efficient mobile layout, **Stormor Shelving** with its accessories, choice of uprights and their colour will improve the efficiency and appearance of the working environment.

**Stormor Shelving** is also effective when used in centralised storage areas, with the slim shelf and upright profiles minimising wasted space within the storage cube. For bulk storage archive boxes the 1250mm wide shelf is designed to carry 3 boxes, giving great economy and maximising storage capacity.

**Stormor Shelving**, with its wide range of sizes and accessories is the right solution to meet the needs of today's modern office environment.

**Ideal for storing.....**

- On-shelf 'live' or 'soft' files
- Hanging files
- Box files
- Lloyd George boxes
- Court Warrant boxes
- Digital data
- Medical records
- Lever Arch files
- Archive boxes
- Reference or Library books
- And much more...



*The Stormor Shelving range is fully compatible with all of our space-saving mobile storage systems, ensuring the maximum utilisation of your available space. For further information refer to our specialist Mobile Systems brochure*



*Interchangeable pull-out accessories can be added into bays to tailor the system and maximise space efficiency.*



*The slim shelf profiles on a 25mm pitch maximise the number of on-shelf filing levels available in a bay, ensuring minimum loss of file storage space.*



*This unique clip simply slots into an upright and is secured with a plastic fitting so that shelves cannot be dislodged accidentally.*



*The design of the standard open shelf allows lateral files to be hung underneath, saving the cost of separate filing cradles.*







## delivering the right storage solution for you

Stormor is also at home in storerooms, rear of store stockrooms, maintenance stores and throughout industry. Its choice of upright styles and shelf duties provides a functional yet attractive system for all stores areas.

Modular design including a range of interchangeable accessories, gives **Stormor Shelving** great scope and capability for the creation of custom-designed storage facilities.

In areas where space is limited, **Stormor Shelving** gives you the capacity to store more than you thought by going mobile. Mobile shelving is space efficient by eliminating the need for several aisles. Because the shelving moves along floor tracks, the space for only one aisle is needed. When access is required to a particular shelving bay an adjacent aisle is created by moving the mobile shelving units apart.

Mobile systems add greatly to the storage capability of retail outlets, hospitals and any space sensitive location.

**Stormor Shelving** offers solutions to small parts storage with its range of bin fronts, dividers, plastic drawers and pull out drawers, ideal for maintenance, automotive, electronic and aerospace operations.



For large high-rise or multi-tier filling and archive installations Stormor's slim profile shelves can be used with our proven Euro-Shelving system to maximise available space.

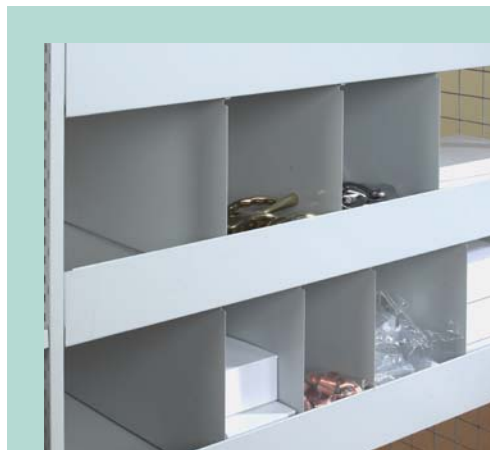

The combination of bin fronts and dividers make Stormor ideal for small parts storage.



Multi position garment rails give great flexibility for seasonal stock changes.



Bin fronts can also be used at the rear of shelves to stop items being pushed across shelves or misplaced.



Storage of small items is achieved with sub-dividable plastic drawer units.



# components & accessories

Stormor Shelving offers more than storage capacity, its range of accessories help to improve working practices and efficiency.

All frames have a 20mm profile and are slotted on a 25mm pitch for shelf adjustment.

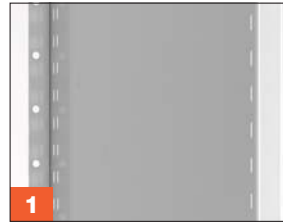

## Solo Frame

Single piece solid frame which features a 20mm delta profile front post with a T-section rear. Frame is pierced with slots on 25mm pitch to accommodate shelf clips.

## Mono Frame

Open shelving frame consisting of a pair of 20mm wide uprights connected horizontally by bracing panels. Available with painted finish as standard or pre-galvanised.

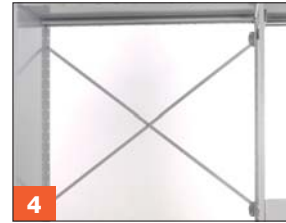
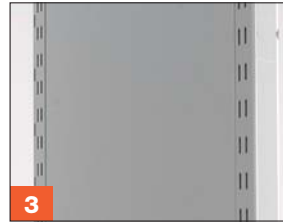

## Duo Frame

Double skinned 20mm box section frame. Allows clear access to the full shelf width, eliminating 'snagging' of items stored. Complies with clear access requirements of BS5454.

## Cross Brace

Provides essential stability bracing for open back shelving bays.

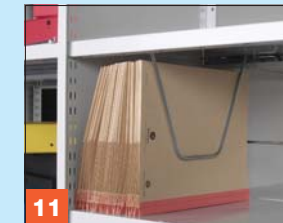
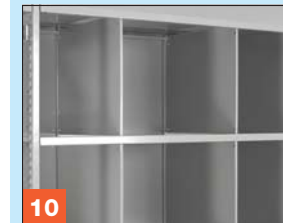
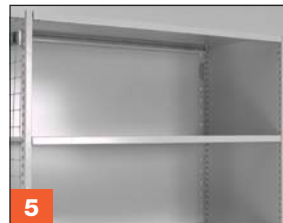
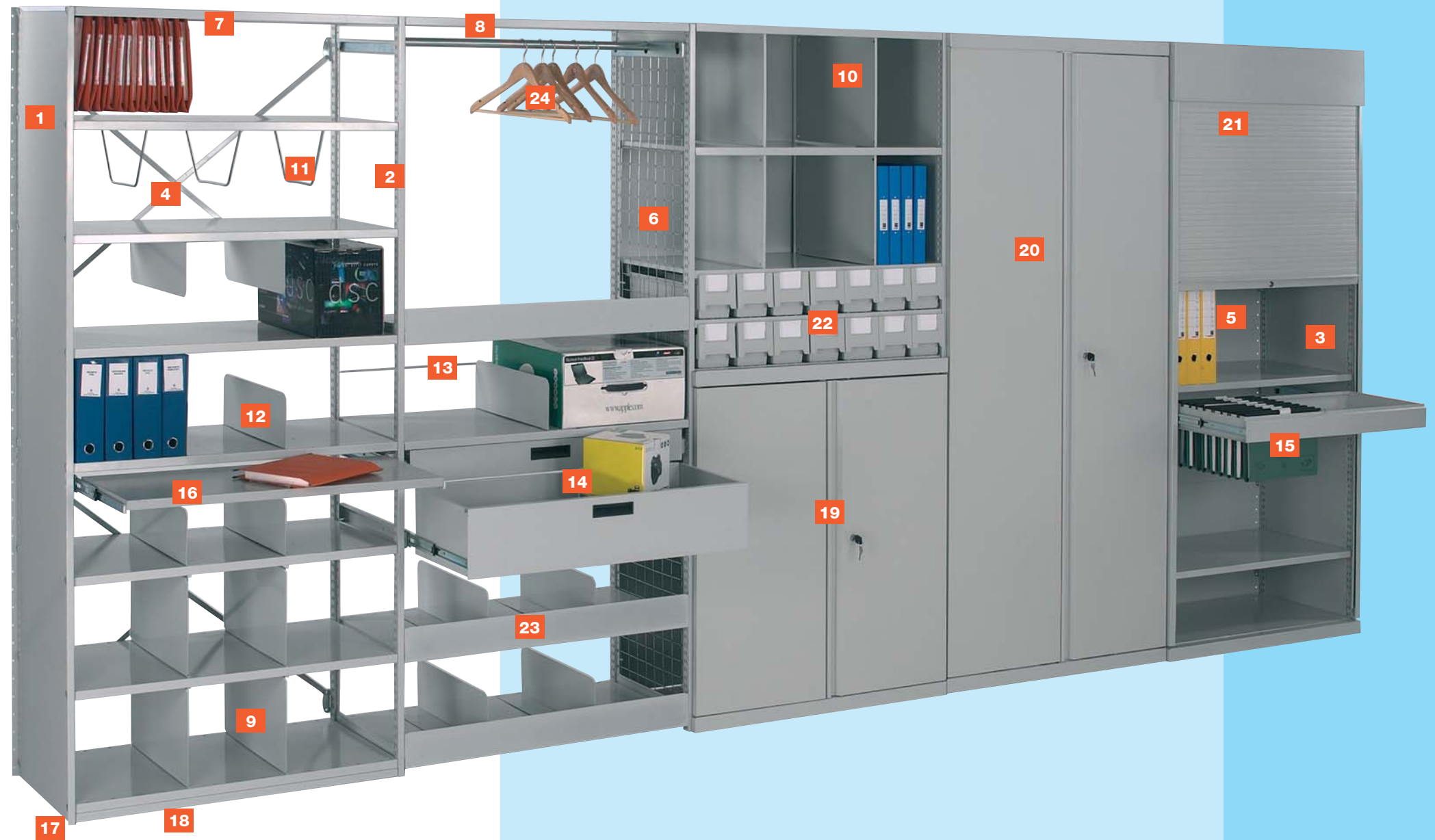

## Rear Cladding

Solid steel sheets that enclose the rear of the bay and give essential stability to the bay structure.

## Mesh Cladding

Can be fitted to open frames and rear cladding for all frame types. Retains visibility and ventilation for the items stored.

## Open Section Shelf

25mm section shelf with a formed open flange which allows lateral files to be hung underneath the shelf. Fits all frames plus Euro Shelving frames.

## Box Section Shelf

25mm box section shelf with formed flange on the front and back for greater load bearing strength. Fits all frames plus Euro Shelving frames.

## Document Divider

Slim profile 'clip-in' divider designed specifically to be used with document storage ensuring minimal wasted space on the shelf.

## General Purpose Divider

Used to divide shelves horizontally into smaller storage compartments. The 'clip-in' divider is easily re-positioned and has a reinforced front edge.

## Under-shelf Divider

Divider simply clips in under the shelf to support books, files etc. Divider can be repositioned as required. For use with open shelves only.

## Part Height Dividers

150mm high divider which slots into either the top or bottom of a shelf to provide storage compartments or support for files or taller material.

## Back Stop

Zinc plated rod which fits across the rear of bays to prevent items falling off the back of a shelf or to segregate a joining shelves. Simply slots into the upright.

## Pull-out Drawer

Fitted onto telescopic slides the pull-out drawer is available in 3 standard heights. Ideal for the storage of CD's, media and other small items within a shelving bay.

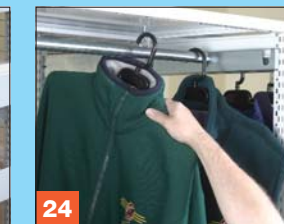
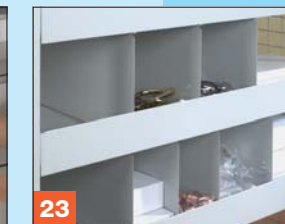
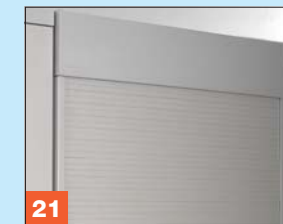

## Pull-out Filing Cradle

Can accommodate A4 and foolscap top loaded suspension files. Cradle slides out on telescopic slides.

## Pull-out Reference Shelf

Slides out from the bay on telescopic slides. Provides a flat and stable work surface within a storage bay. Fits all frame types.

## Frame Floor Clip

Simple clip-in bracket which allows all types of Stormor frames to be floor fixed. Can be shimmed by using Stormor shim plates. Fits within bay footprint.

## Floor Plinth

Floor plinths prevent dust and debris collecting under the shelving. Simply clips to the underside of shelf to create a smooth overall finish of the front face.

## Half Height Door

Hinged door 1100mm high. Creates secure storage cupboard within shelving. Doors are stiffened to the full height and have 2-point locking, recessed handle and safety key.

## Full Height Door

Hinged doors transform shelving into a lockable storage cupboard. Doors feature full height vertical stiffener, 2-point locking recessed handle and safety key.

## Tambour Door

Roller shutter doors for security and dust protection of items stored. Open door does not protrude into aisle making tambours ideal for lockable storage in limited space.

## Plastic Drawers

Ideal for the storage of small items. Available in 3 sizes, the drawers tilt on integrated back-stops to allow easy viewing and access and can be sub-divided.

## Bin Fronts

Prevent items falling off the front of shelves and when used with shelf dividers form enclosed compartments or 'bins'.

## Garment Hanging

System of rails and brackets which fit within bay widths to allow the hanging of garments. Rails can be re-positioned as required.

# availability & colours

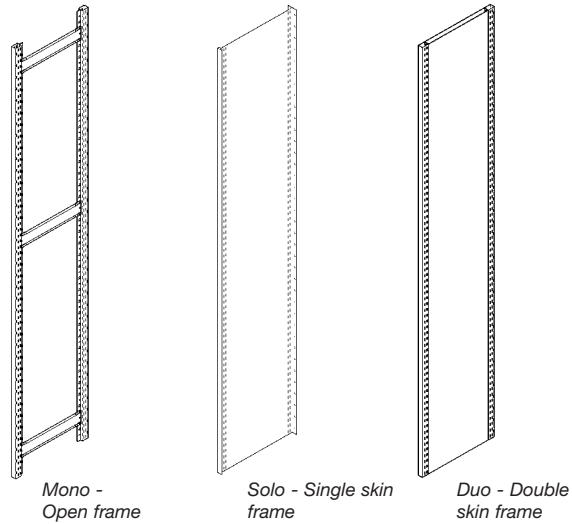

## All Frames

Height (nominal mm)	Depth (nominal mm)
950 1100 1250	200 225
1400 1550 1700	250 270
1850 2000 2150	300 320
2300 2450 2600	350 370
2750 2900 3050	400 450
3200 3350 3500	500 600

**Open Section Shelf**  
Available in three duties for varying load requirements.

Standard Pierced Shelf

Width (nominal mm)	Depth (nominal mm)
600 700 750	200 225
800 900 1000	250 270
1100 1250	300 320
	350 370
	400 450
	500 600

Unpierced Shelf available on request

**Box Section Shelf**  
Available in three duties for varying load requirements.

Standard Pierced Shelf

Width (nominal mm)	Depth (nominal mm)
900 1000	300 320
1100 1250	350 370
	400 450
	500 600

Unpierced Shelf available on request

**Pull-out Suspension Cradle**

Width (nominal mm) (= bay width)	Depth (nominal mm) (= shelf depth)
1000	370 400 450

**Pull-out Reference Shelf**

Width (nominal mm) (= bay width)	Depth (nominal mm) (= shelf depth)
1000	370 400 450

**Pull-out Drawer**

Width (nominal mm) (= bay width)	Depth (nominal mm) (= shelf depth)
1000	370 400 450

Heights (nominal mm)  
100 150 200

**Plastic Drawer Units**

Type	Height	Width	Depth
DU1	138	138	281
DU2	138	207	281
DU3	138	138	431

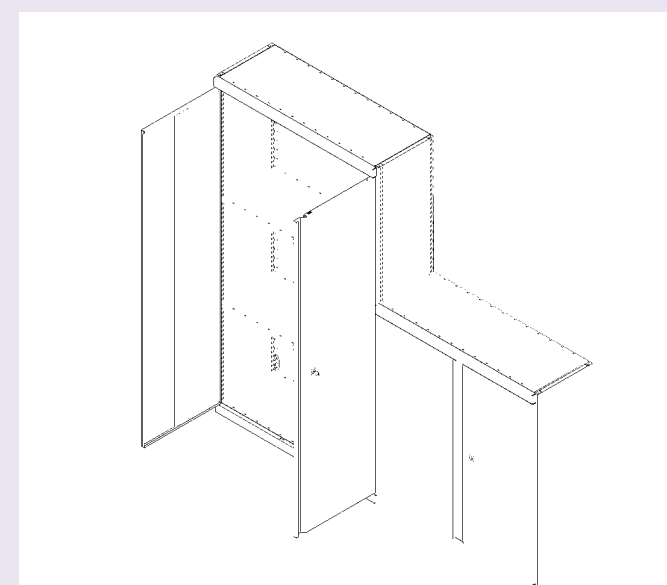

**Pin Hinge Door**

Height (nominal mm)	Width (nominal mm) (= shelf width)
1100 1850 2150	1000

**Tambour Door**

Height (nominal mm)	Width (nominal mm) (= shelf width)
1850 2150	1000

**Floor Plinth**

Height (nominal mm)	Width (nominal mm) (= shelf width)
23 (50mm including base shelf)	600 700 750 800 900 1000 1100 1250

**Document Divider**

Height (nominal mm) (= shelf pitch)	Depth (nominal mm) (= shelf depth)
125 150 175	200 225 250
200 225 250	270 300 320
275 300 325	350 370 400
350 375 400	450
425 450	

**General Purpose Divider**

Height (nominal mm) (= shelf pitch)	Depth (nominal mm) (= shelf depth)
150 175 200 225	200 225 250
250 275 300 325	270 300 320
350 375 400 425	350 370 400
450 475 500 525	450 500 600
550 575 600	

**Under-shelf Divider**

Height (nominal mm) (= shelf pitch)	Depth (nominal mm) (= shelf depth)
150 200	150 high: 200 high:
	200 - 250 270 - 320
	350 - 400
	450 - 500
	600

**Part Height Divider**

Height (nominal mm) (= shelf pitch)	Depth (nominal mm) (= shelf depth)
150	200 225 250 270 300 320 350 370 400 450 500 600

**Back Stop**

Height (nominal mm)	Width (nominal mm) (= shelf width)
4 diameter	600 700 750 800 900 1000 1100 1250

**Bin Front**

Height (nominal mm)	Width (nominal mm) (= shelf width)
25 50 75 100	600 700 750 800 900 1000 1100 1250

**Garment Hanging Rail**

Width (nominal mm)	Depth (nominal mm) (= shelf depth)
0900 1000 1100 1250	300 450 600

**Standard Component Colours** Swatches shown give an approximate colour guide only.

Shelf/Cladding and Accessories Colour	Upright Colours			
Stormor Grey - RAL 7035	Stormor Grey - RAL 7035	Traffic Red - RAL 3020	Marine Blue - RAL 5001	Racing Green - RAL 6005
	Sauve Blue - BS 5252 20 E 56	Graphite Grey - BS 5252 18 A14	Euro Green - RAL 6011*	Burgundy - BS 5252 04E 58*

\* Denotes available on Extended Leadtime.